



STATE OF NEVADA
 COMMISSION ON MINERAL RESOURCES
DIVISION OF MINERALS
 400 W. King Street, Suite 106
 Carson City, Nevada 89703
 (775) 684-7040 | Fax (775) 684-7052
 http://minerals.nv.gov

Date Received 11/19/21
 County NYE
 NDOM Permit Number W0008
 FOR DIVISION USE ONLY

DISSOLVED MINERAL RESOURCE EXPLORATION WELL PERMIT APPLICATION

Applicant/Operator Name: 3PL Operating, Inc.
 Street Address: 1802 N. Carson Street Suite 154
 City: Carson City State/Prov.: Nevada
 Country: USA Zip Code: 89701

hereby makes application for a dissolved mineral resource exploration well permit.

(if applicant is a corporation, show state and date of incorporation; if a partnership, list names of partners.)

State: Nevada
 Formation Date: 4 October 2017

Well Name Li 11-18

This application is for a: New Exploration Well Borehole to Well Conversion
 Permit Extension (NDOM Permit # _____) (Indicate below any changes to original permit)
 Permit Extension Reason: _____

Applicant is: Land Owner Lease/Claim Holder

Land Status (choose one):

Federal (BLM, USFS, etc...)
 Mining Claim: NMC# 101555358
 Project Name: RRV II Exploration Project, Amendment 1 NVN# NVN-100052

Non Federal
 APN#: _____ Land Owner: _____
 Bond Type: _____ Issued by: _____
 Amount: _____ Number: _____

Groundwater Basin Name and Number Railroad Valley North, 173B Area With Limitations? Y N

(Well proposed to be drilled within areas with limitations may require Blowout Prevention Equipment, per NAC 534B)

Location of Well:

County: Nye

NW 1/4 of the NW 1/4 of 18 Sec., Township 7 N S, Range 56 57 CP E

UTM East: 620655.90 or Longitude: _____
 UTM North: 4259126.23 Latitude: _____
 NAD83 WGS84 M.D.B. & M.

Drilling Contractor (if known): Welsco Corp
Address: PO Box 5245
City, State Zip: Fallon, NV 89407

Purpose of Well: Mineral Exploration
Drill Rig Type: Mud Rotary
Surface Hole Diameter: 17.5 Inch Casing Size/Length: 13.375-in / 500 ft & 7-in / 2301.5 ft
Expected Total Depth: 2,300 Feet Casing Weight/Gauge: 48# & 29#
Casing Schedule/Grade: H-40 & L-80

Blowout Prevention Equipment Rating: None 2000 psi 3000 psi 5000 psi
>1000 psi rotating head

Fluid Management Plan (NAC 534B):

Please see attached narrative, Section 4.0.

(Describe Here or Attach Additional Pages)

Contamination Prevention/Cementing Plan (NAC 534B):

Please see attached narrative, Section 1.0.

(Describe Here or Attach Additional Pages, must include Well Schematic)

Flow Monitoring and Plugging Plan (NAC 534B):

Flow will be recorded by mechanical totalizer and ultrasonic meter. Pursuant to Nevada Administrative Code 534B Section 35.1(a), perforated sections of the casing will be plugged by placing cement grout by tremie pipe in an upward direction from the bottom of the well to 100 feet above the uppermost perforated casing or to the surface. Unperforated portions of the well 100 feet above the plug may be plugged pursuant to NAC 534B Sec 35.3 with uncontaminated fill to within 20 feet of the surface. The remaining 20 feet of casing will be plugged with cement grout. See Section 4.1.

(Describe Here or Attach Additional Pages)

↓ NAC 534B.180(3) CPL

Drilling will commence approximately on: 29 November 2021

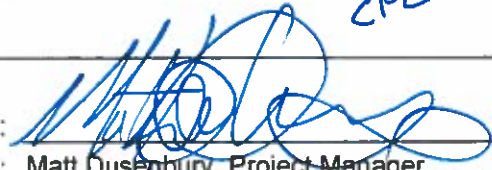
Signature of Applicant/Agent: 
Printed Name/Title: Matt Dusenbury, Project Manager
Date: 11 Nov 2021

An application submitted without a signature and date will not be considered for approval.

-----Attach \$1,000.00 Application Fee Per NAC 534B-----

----- TO BE COMPLETED BY DIVISION -----

CONDITIONS OF PERMIT

1. All permittees must comply with appropriate sections of the Dissolved Mineral Resource Regulations of the Division of Minerals and with applicable rules and regulations of state and federal agencies.
2. For a well located on non-federal land, a bond in an amount determined by the Division to be necessary to properly plug the well in accordance with NAC 534B must be included.
3. Well Permit Expires two (2) years from date of approval.
4. See attached Conditions of Approval.
5. Send any required reports to: ndom@minerals.nv.gov
6. Additional Conditions/Comments

A.	Evidence of a bond acceptance by the BLM must be provided by the operator and received and acknowledged by the Division before the drilling of the proposed well commences.
B.	
C.	

This permit does not extend the permittee the right of ingress and egress on public, private or corporate lands.

The issuance of this permit does not waive the requirements that the permit holder obtain other permits from State, Federal, and local agencies.

PERMIT APPROVAL

Approved 11/19/2021 with the conditions noted above.
Date

Permit Number _____



Administrator
Division of Minerals



STEVE SISOLAK
Governor

STATE OF NEVADA
COMMISSION ON MINERAL RESOURCES
DIVISION OF MINERALS
400 W. King Street, Suite 106
Carson City, Nevada 89703
(775) 684-7040 • Fax (775) 684-7052
<http://minerals.nv.gov/>



MICHAEL VISHER
Administrator

Las Vegas Office: 375 E. Warm Springs Rd. #205, Las Vegas, NV 89119
Phone: (702) 486-4343; Fax: (702) 486-4345

**DISSOLVED MINERALS RESOURCE
Li 11-18 EXPLORATION WELL
CONDITIONS OF APPROVAL**

Submit forms and correspondence to: Nevada Division of Minerals
400 West King Street
Suite 106
Carson City, NV 89703

Communications with the Division shall be directed to:

Cortney Luxford, Fluid Minerals Program Manager
Office 775-684-7045 Email cluxford@minerals.nv.gov
Cell 775-721-1774
Fax 775-684-7052

Michael Visher, Division Administrator
Office 775-684-7044 Email mvisher@minerals.nv.gov
Cell 775-721-7625
Fax 775-684-7052

Voicemail is available on all cell phones and office phones. Please leave a message if you are unable to speak to someone and we will return your call as quickly as possible.

YOUR APPLICATION TO DRILL THE Li 11-18 EXPLORATION WELL IS APPROVED SUBJECT TO THE FOLLOWING PERMIT CONDITIONS

1. All actions related to the drilling of this exploratory well must abide by the statutes set forth in Nevada Administrative Code 534.B and cementing set forth in Nevada Administrative Code 534.B
2. A licensed water well driller must be on location during the drilling operations of this well.
3. When drilling a dissolved mineral resource exploration well, a well driller shall:
 - a. Isolate zones of varying water quality to prevent the migration of fluids between aquifers;
 - b. Prevent the contamination or waste of groundwater; and
 - c. Minimize damage to the environment, ground and surface waters, property and any known oil, gas or geothermal resources
4. These conditions of approval (COA's) and the minimum Blowout Prevention Equipment (BOPE) requirements, if required by the Division or utilized, shall be posted at the well site and read by all company personnel associated with the subject well.

5. If an artesian condition is encountered in a dissolved mineral resource exploration well, such that water is flowing at the surface, the well driller shall ensure that an unperforated casing extends through the confining strata above the artesian zone. The annular space between the casing and the walls of the well bore must be sealed by placing neat cement, cement grout or bentonite chips by tremie pipe in an upward direction from the top of the artesian zone to the level necessary to prevent the leakage of artesian water above or below the surface.
6. Any flow of artesian water must be stopped completely using any necessary valves, plugs or other appliances to prevent or control the flow of water from the dissolved mineral resource exploration well and prevent the loss of groundwater above or below the ground surface before the drill rig is removed from the drill site.
7. The operator of a dissolved mineral resource exploration well shall:
 - (a) Install a water meter capable of measuring the total withdrawal of water from the dissolved mineral resource exploration well.
 - (b) Maintain an accurate record of meter readings, including the serial number of the meter.
 - (c) Submit to the Division, on a form designated by the Division, a quarterly report which includes the serial number of the meter and the meter readings from the dissolved mineral resource exploration well. The quarterly report:
 - (1) Is required for each month beginning with the commencement of drilling operations until the later of the expiration of the permit or until the dissolved mineral resource exploration well is plugged; and
 - (2) Must be filed with the Division on or before the last day of the month following the month in which the meter is read.
 - (d) Ensure the total withdrawal of water from the dissolved mineral resource exploration well project does not exceed 5 acre-feet.
 - (e) Comply with the appropriation procedures of chapters 533 and 534 of NRS if water is pumped from the dissolved mineral resource exploration project in excess of 5 acre- feet.
9. The well driller shall:
 - (a) Keep a record of the depth, thickness and character of the different strata penetrated and the location of the water-bearing strata;
 - (b) Keep an accurate record of the work, including, without limitation:
 - (1) A statement of the date that work begins;
 - (2) The date of completion of the dissolved mineral resource exploration well;
 - (3) The name and the type of machine used to drill;
 - (4) The length, size and weight of the casing and how it is placed, including, without limitation, a description of any perforations;
 - (5) The size of the hole that is drilled for the dissolved mineral resource exploration well;
 - (6) Identification of the water-bearing strata;
 - (7) The maximum temperature of the water in the dissolved mineral resource exploration well measured in degrees Fahrenheit; and
 - (8) If a seal was installed, the interval sealed off and the type of seal; and
 - (c) Submit a report of the record of the work to the Administrator on a form designated by the Division. The report must be provided by the well driller to the Administrator for every dissolved mineral resource exploration well that is drilled not later than 30 days after the well is completed.
10. (1) A dissolved mineral resource exploration well must be plugged by:
 - (a) A well driller before the expiration of the permit, unless a waiver or permit is issued by the State Engineer to change the status of the dissolved mineral resource exploration well.
 - (b) Placing neat cement, cement grout or bentonite grout by tremie pipe in an upward direction from the bottom of the well to 100 feet above the uppermost perforated casing or to the surface of the dissolved mineral resource exploration well.
 - (c) Removing the pump and any debris from the well bore with appropriate equipment.

(2) Cement plugs must:

(a) Be placed in the uncased portion of all dissolved mineral resource exploration wells to protect all subsurface resources.

(b) Be placed to isolate formations and to protect the fluids in those formations from interzonal migration.

(c) Extend a minimum of 100 lineal feet above the producing formations and 100 lineal feet below the producing formations or to the total depth drilled, whichever is less.

(3) A well driller may use uncontaminated fill from the top of the plug installed in accordance with subsection 1 to within 20 feet of the surface of the dissolved mineral resource exploration well. The well driller shall place a surface plug in the dissolved mineral resource exploration well consisting of neat cement, cement grout or concrete grout from a depth of at least 20 feet to the surface of the dissolved mineral resource exploration well.

(4) All casing strings must be cut off below ground level and the casing stub must be permanently capped.

(5) The surface must be restored as near as practicable to its original condition.

(6) If conditions are encountered which prevent compliance with this section, the operator or well driller must submit an alternative plugging plan to the Division for the approval of the Division.

(7) The operator or well driller shall file a plugging report to the Division on a form designated by the Division and available on the Internet website of the Division. The report must be signed by the well driller documenting proper plugging of the dissolved mineral resource exploration well not later than 30 days after completion of the work.

(8) The owner and lessor of the land on which the dissolved mineral resource exploration well is located, the operator and the well driller are jointly and severally responsible for plugging the dissolved mineral resource exploration well pursuant to this chapter.



9 November 2021

Via E-Mail: (cluxford@minerals.nv.gov)

Via Certified Mail

Mr. Cortney Luxford
Fluid Minerals Program Manager Nevada
Nevada Division of Minerals
400 West King Street, Suite. 106
Carson City, NV 89703

**Re: 3PL RRV II Exploration Project NVN-100052
Dissolved Mineral Resource Exploration Well Permit Applications**

Dear Mr. Luxford,

Pursuant to Nevada Administrative Code (NAC) 534B.110, 3PL Operating, Inc. (3PL) submits the attached Dissolved Mineral Resource Exploration (DMRE) Well Permit Applications for two (2) new wells in Railroad Valley, Nye County, Nevada, Li 10-28 and Li 11-18. The project area is located about 110 miles east-northeast of Tonopah, Nevada. Pursuant to NAC 534B.140.2, the fee for each Application is \$1,000. A fee for four (4) proposed wells, totaling \$4,000, was paid by check on 12 August 2021. 3PL withdraws from consideration the associated 12 August 2021 application and provides instead this application for two (2) different exploration wells. 3PL requests \$2,000 of the \$4,000 paid be allocated instead to accommodate the two (2) wells proposed herein.

Proposed wells will be completed on Bureau of Land Management-administered federal lands in the Battle Mountain District (Tonopah Field Office) as part of an Amendment to the authorized Notice NVN-100052. The Amendment will be submitted to the Tonopah Field Office concurrent with this DMRE application. The total proposed Reclamation Cost Estimate, including well abandonment, is \$429,117.

1.0 Well Construction Details

Up to two (2) total drill rigs will be operating simultaneously during the Project. All wells will be drilled under the supervision of a licensed well driller. One (1) conventional well drilling rig will set pre-collars and cement the conductor pipe for all wells. All pre-collared holes will be equipped with a secure cap to prevent anything falling in. The conventional well rig will set pre-collars for Li 10-28 and 11-18. One (1) portable mud rotary drill rig will follow the conventional rig and enter the pre-collared and cased holes to deepen to total depth and complete wells Li 10-28 and 11-18. The mud rotary rigs will set and fully cement surface casing, retrieve core samples, and set and fully cement production casing. One (1) new sump will be constructed for each well drilled. Well construction details are included in the attached Applications (Appendix 1). Rotating heads with pressure ratings of greater than 1,000 pounds per square inch will be used for blowout control on each well. The proposed amount of cement to be used in each well is summarized in Table 1.

Table 1. Cement volumes for proposed wells (cubic feet).

Casing String	Well Name	
	Li 10-28	Li 11-18
Conductor	65.99	65.99
Surface	663.52	559.33
Production	1858.9	1858.9

One (1) mud rotary rig and one (1) conventional rig will be used to complete wells Li 10-28, and Li 11-18. Wells Li 10-28, and Li 11-18 will be constructed to depths of up to 2,300 feet bgs. Groundwater is estimated to be about 50 feet bgs at Li 10-28 and 40 feet bgs at Li 11-18. To construct Li 10-28 and Li 11-18, the conventional rig crew will first excavate a six (6)-foot diameter by four (4)-foot deep cellar with a backhoe or equivalent equipment. Excavated material will be stored near the edge of the drill site for reuse at reclamation. The volume of each cellar will be about four (4) cubic yards. The cellar will provide space for wellhead equipment, including the blowout preventer. The conventional rig will then enter the cellar and drill a 26-inch diameter pre-collar to 55 feet bgs. A 20-inch diameter conductor pipe will be cemented in the 55-foot pre-collar. All wells will be completed with a fully cemented conductor pipe. The conductor pipe prevents drilling fluids from saturating the ground around the well and prevents native formation fluids from entering the wellbore. Shallow brine, if present, may be sampled for characterization after installation of the conductor pipe. Additional detail on sample methodology is included in Section 4.5. The conventional rig will then leave the site.

The mud rotary rig will then enter the pre-collared hole and advance a 17.5-inch diameter surface hole to depths of up to 600 and 500 feet bgs for wells Li 10-28, and Li 11-18, respectively. A 13.375-inch surface casing will be cemented into the surface holes. Surface casing lengths are placed to a minimum depth of 100 feet below the base of fresh water to protect the upper aquifer. The base of fresh water is estimated from local vertical electrical sounding surveys, magnetotelluric surveys, and petrophysical analyses as detailed in Appendix 3. The cemented steel surface casing prevents any fluids from entering the fresh water aquifer while advancing drilling to the total depth. An 8.75-inch diameter core bit will then be advanced from the bottom of the surface hole to up to 2,300 feet bgs to collect selective core samples of four (4)-inch diameter. An 8.75-inch diameter US Coring X2 Tough Drilling core bit, or similar, will then be advanced from the bottom of the surface hole to up to 2,300 feet deep to collect selective core samples of four (4)-inch diameter. The core bit specifications are included in Appendix 6. The mud rotary rig will then re-enter the surface 13.375-inch casing and widen the 8.75-inch diameter production hole to a 12.25-inch diameter borehole to the total depth of up to 2,300 feet bgs. A seven (7)-inch diameter L-80 production casing will be set to the total depth of up to 2,300 feet bgs. The seven (7)-inch diameter production casing will be cemented the full length to the total depth of 2,300 feet bgs. Production casing will be perforated at selected intervals from 800 feet bgs to 2,300 feet bgs. Production casing will be perforated at selected intervals from 800 feet bgs to 2,300 feet bgs. The proposed HERO® Scalloped Gun System SDP charges (or similar) are rated for penetration of up to about 47 inches of solid rock and will be effective in perforating the seven (7)-inch diameter cemented casing and 12.25-inch wellbore (Core Laboratories, 2021). The cemented production casing will

prevent any deep formation fluids from migrating upward towards the fresh water aquifer. Casing stickup will be about 18 inches above ground surface. Well construction detail for Li 10-28 and Li 11-18 is included in Appendix 1.

One (1) pump will be used to access fluid in the Project wells after completion. Pumping will be conducted to collect subsurface data including aquifer yield, mineral concentrations, and changes in mineral concentrations over time. Sampling of fluid is described in Section 4.5. Any excess fluid from pumping will be captured in surface tanks as described in Section 4.5. One (1) pump will be installed to a depth of up to 2,000 feet below ground surface. 3PL will reuse the pump, moving it to other wells in the Project area for fluid sampling as needed. No more than one (1) pump will be installed in the Project area without amendment to the Notice and posting of the appropriate bond amount.

2.0 Geologic Resources

Railroad Valley is located in east-central Nevada between the Pancake Range and Grant Range (Figure 4). Sedimentary and volcanic rocks ranging in age from Quaternary to Paleozoic have been penetrated by 292 oil and gas exploration and production wells. The Railroad Valley area is a unique region with sedimentary facies related to active tectonism which became pronounced in early Pliocene time and formed a closed basin depocenter.

Major structural elements of the Railroad Valley area are shown in Figure 4. Each mountain range, including the Grant Range and Pancake Range, is a large-scale asymmetric anticline, with the western limb steepest. Tertiary strata are folded and faulted on each of these structures, and mostly eroded from the crestal areas. Noteworthy is an anticline on the Railroad Valley floor, just south of the playa, where Recent playa sediments are folded upward in the core of an active anticline. Several thrust faults are shown that are identified as a result of this study, and others exist, but are not yet mapped.

A detailed geologic cross section, shown in Figure 5, is constructed across Railroad Valley, using well data from several dozen wells, and outcrops from the surrounding mountain ranges. The Pliocene evaporite deposits of this study are shown in gray in the center of Railroad Valley, and these deposits are slightly deformed. Several of the thrust faults shown are penetrated by wells, and demonstrate that older strata overlie younger strata. Also, many of these faults are mapped at the surface. Several points of major interest are apparent, notably the asymmetry of the Pancake Range, with intrusion of Pliocene basalt in the core of the anticline. Eocene strata in the subsurface of the Railroad Valley, shown in light orange color, are the most perplexing unit, because half of this unit is missing – the western half. As currently distributed, the Eocene rocks only exist on the east side of the Valley, and thin eastward by erosion. This deposit does not exist on the west side, and therefore is buried beneath the thrust sheet that lies beneath Eagle Spring oil field. This relationship implies that at least five (5) miles of shortening must have occurred along this fault, and the distance could be much greater. Outcrop studies along the front of the Grant Range confirm this amount of movement in the late Tertiary (Ramirez, 2020).

2.1 *Geologic Evolution of Railroad Basin*

Eocene through Miocene time represents the “pre-deformation” period of Nevada Tertiary strata. These rocks are interpreted to have formed in a large intercontinental basin that extended from Utah to westernmost Nevada, and apparently connected the Green River area of Wyoming to California (Stokes, 1979). Extensive evaporite deposits exist within these rocks.

Early Pliocene time marks the onset of major deformation in Nevada. Thrust faults, powered by east-west compression, are clearly visible in the range fronts throughout the region, and many are still active. At this time, the large intercontinental basin was reorganized into its current valley-and-mountain setting (commonly called “basin-and-range”), and the low-lying areas were filled with sediments. Coincident to this compression, extensive olivine basalt erupted throughout the area, particularly in the cores of anticlines and along thrust faults, as seen in Railroad Valley and elsewhere. Miocene strata are strongly deformed and uplifted around each mountain range in Nevada and typically are nearly parallel to deformed older strata on all flanks (Ramirez, 2013). Miocene strata are inferred to have existed across the top of each range prior to uplift and subsequent erosion, and now are preserved in the inter-montane synclines where they typically are 10,000 ft thick.

2.2 *Stratigraphy*

The stratigraphic section in Railroad Valley consists of PreCambrian rocks, Ordovician Eureka Quartzite, Devonian Guilmette Limestone, Cretaceous sedimentary rocks, Eocene Sheep Pass Formation, Oligocene volcanic rocks, Miocene Blind Springs Formation, Pliocene Basalt, and a Pliocene evaporite sequence (Figure 5).

The Oligocene volcanic rocks near Railroad Valley, known as the Garrett Ranch Group, include more than 3,000 feet of tuff, and typically are densely welded and andesitic or rhyolitic. Originally extending over hundreds or thousands of square miles, these volcanic rocks now mostly are eroded from elevated areas.

The Oligocene Garrett Ranch Group is overlain by the Miocene Blind Springs Formation, a red-bed coarse clastic unit with thick limestone beds, and folding in these units demonstrates that deformation is younger. There is a pronounced angular unconformity at the valley margins where the Blind Springs Formation rests upon truncated Oligocene volcanic rocks and older strata, and this illustrates that the current basin configuration had a precursor geometry since about Middle Miocene time.

The focus of this project is the Pliocene and younger section, which contains a “super-brine complex” consisting of evaporite minerals, including complex salts, and a co-existing hypersaline brine. The Pliocene stratigraphic section of Railroad Basin consists of a volcanic unit (basalt and tuff), which is conformably overlain by an evaporite sequence that is up to 2,000 feet thick. Overlying the evaporite section is a progradational clastic sequence that grades upward from clay to conglomerate, which appears to have been deposited during the Quaternary, but we cannot precisely identify its age.

2.2.1 Data Set

Data used in this study to interpret the lithologies include mud logs and lithology logs from a data set of 292 oil wells drilled in Railroad Valley, as well as drill cutting descriptions and X-Ray Diffraction (XRD) analyses of drill cuttings (also termed “drill solids”) from 3PL’s discovery well, LD 1-32. The stratigraphy is correlated and geologic units are mapped using suites of wireline electric logs from oil wells, as well as 10 miles of 2D seismic-reflection data acquired by 3PL. The depth to the top of the brine is determined from 40 miles of magnetotelluric (MT) data acquired by 3PL, and from a vertical electrical sounding (VES) survey acquired by 3PL. The depth to base of brine is determined from petrophysical analyses of resistivity logs from oil wells and LD 1-32.

2.2.2 Pliocene Basalt

The Pliocene basalt is a complex volcanic unit consisting of a black basaltic ash-fall tuff, brown sandstone (locally), up to three basalt flow units, and a light-colored crystal lithic tuff. The thickness of this unit ranges from 30 ft to 241 ft across the basin, depending on whether it consists of one or three basalt flows. The base of the basalt generally is at a depth of about 2,200 ft measured depth (MD) in Railroad Basin (Figure 6). This unit is mapped in the subsurface from wireline electric logs, and is examined in outcrop in the Grant, Quinn, and Pancake Ranges.

The basalt flows appear to have originated from thrust faults along the western front of the Grant Range, as well as along the eastern front of the Pancake Range. Significantly, the thickest basalt units (189 ft to 241 ft thick at wells 27 023 05003, 05306, 05310, and 05496) are located along the western front of the Grant Range, just basinward of a major thrust fault. Because the basalt flows have a linear morphology, they are not present at some well locations; however, the black basaltic tuff probably is ubiquitous throughout the basin.

The base of the Pliocene basalt is a time-stratigraphic surface, an angular unconformity along the basin margin, and marks a significant change in the tectonic history of the basin. We estimate the age of this volcanic unit to be 3 million years, based on a depth of burial of 2,196 ft (at well 27-023-05495), and an analogous sedimentation rate of 22 cm/1,000 years at Searles Lake (Smith, 2009).

2.2.3 Evaporite Sequence

Conformably overlying the Pliocene Basalt is an evaporite sequence that ranges in thickness from 550 to up to 2,000 ft within the project area.

This section primarily consists of interbedded clay or claystone or marlstone and salt beds (including halite and complex salts), with lesser amounts of volcanic ash, and rare sandstone and conglomerate. Gaylussite (pirssonite) is a common constituent of the claystone and marlstone.

This conformable section of evaporites and claystone is interpreted to have been deposited in a closed-lake basin, and these strata are indicative of a quiescent, low-energy depositional system dominated by fine-grained sedimentation of salt and clay. 3PL’s map of ancient shorelines along the perimeter of Railroad Valley combined with subsurface analyses leads to the understanding that the Pliocene Lake

Railroad filled this basin to depths of at least 600 feet and then evaporated for 100 cycles over a two (2) million-year period, leaving layers of salt and other evaporite minerals (Loomis and Ramirez, 2020).

2.2.4 Siliciclastic Sequence

Overlying the evaporite sequence is a sequence boundary at a depth of 1,220 ft in well 05495, which is south of the project area to be drilled by 3PL. Evaporite salts and claystone dominate below the sequence boundary, and clastic sediments that grade from clay to sand to pebbles are the predominant lithologies above the sequence boundary near wells 05495 and LD 1-32. This boundary marks an abrupt change from the quiescent, low-energy depositional setting of the evaporite sequence to high-energy progradation of siliciclastics into the basin.

The grain size and thickness of this overlying siliciclastic sequence is expected to decrease toward the center of the playa.

The lowermost part of the siliciclastic sequence contains salt. The presence of salt in this shallow section indicates that the ancient Railroad Lake continued to experience cycles of evaporation and drying as it alternated between a residual and dry lake.

3.0 Hydrologic Resources

Seeps or springs or other surface water bodies located within at least one-half (0.5) mile of proposed activities are indicated in Figure 9.

In the subsurface of Railroad Valley, the lithologies associated with the hypersaline, saturated brine are complex salts, including natron, nahcolite, tychite, northupite, and pirssonite. There is a complex relationship between the minerals in the brine and the solid salts that have precipitated from it. The concentration of the various elements, including mineral commodities, varies according to the solubility coefficients, temperature, and pressure of each salt at lined basin conditions. Therefore, salts of the evaporite sequence exist at shallow depths in the center of the playa also.

Both the MT and VES data suggest that this 32 percent by weight salinity brine reaches the surface in the center of the playa. The center of the playa is a hostile environment where no plants live, which possibly is another indicator that the highly alkaline, hypersaline brine reaches the shallow subsurface in this area.

Subsurface analyses indicate that freshwater aquifers exist primarily on the north, east, and south sides of the basin, and consist of coarse-grained sediments and fresh water derived from the Grant Range on the east, as well as older fluvial systems from the north and south. The MT and VES data indicate that these wedge-shaped aquifers pinch out toward the center of the playa.

At Li 10-28, the top of the brine and base of the freshwater aquifer is estimated to be at a depth of about 358 feet below ground surface. At Li 11-18, the top of the brine and base of the freshwater aquifer is estimated to be at a depth of about 300 feet below ground surface.

Depth to groundwater in the Project area varies from about 80 feet below ground surface near LD 1-32, near 50 feet bgs at 10-28 and about 40 feet bgs at Li 11-18. The general direction of groundwater flow in the Project area is toward the center of the playa converging from the east and the west.

4.0 Fluid Management Plan

3PL proposes to drill using a closed-loop “mud” (drilling fluid) circulation system. Hydrological control of the borehole is maintained by controlling drilling fluid losses and gains with the use of specially selected drilling products and associated materials added to make-up water. Appropriate selection of drilling fluids provides a balance of wellbore pressures resulting in negligible comingling or migration of fluids to the surrounding formations. The drilling fluids are adjusted during drilling with depth and aquifer characteristics. This produces a drilling fluid with chemical and physical properties that build a filter cake that “seals” the borehole and adjacent bedrock from significant loss or gain of fluid in the borehole. The differential pressure created by the increase in fluid density in the borehole is controlled to be greater than the formation pressures. Safety Data Sheets for all proposed drilling fluid products are included in Appendix G of the BLM Notice Application (Appendix 4, electronic only). None of the proposed drilling fluid products are hazardous. All drilling fluid products will be stored in a manner consistent with the product manufacturer recommendations and that will not present hazards to wildlife or other animals and prevent any release to the environment. Bagged or dry bulk materials will be covered, and any liquid additives will be kept in secure, leak-proof containers. Spill prevention detail and information about management of all consumable materials and waste for the Project is included in Section 5.0.

Drilling fluid products will be used as a circulating medium to lubricate and cool the bit and drill rods, control borehole fluid losses or gains, and remove cuttings or solids from the borehole during drilling operations. The drilling fluid will be continuously adjusted to ensure compatibility with the salinity, pH, and carbonate content of the formation fluids and the respective intervals to be cored. The proposed fluid mixes will ensure a near native-state core can be recovered. All proposed drilling fluid products will be used as intended by the product manufacturer.

The proposed drilling method assures 3PL will have the ability to collect geological samples to the targeted drill depths while maintaining hydrological control of the borehole during drilling operations with the smallest equipment footprint required. Safety Data Sheets will be kept on site for all materials used. Quantities of drilling fluid materials that are present on the project will be limited to those necessary to do the job, which may include hydraulically terminating artesian flow should it be necessary.

Drilling fluid density, pump pressure, and pump flow rates will be carefully monitored to prevent significant fluid losses to surrounding formations from the borehole. Increasing drilling fluid density increases the differential pressure accordingly and serves as the primary control for any fluid gains into the borehole that might also become artesian during drilling operations. The drilling fluid is continuously monitored, and the physical and chemical properties continuously adjusted by the

addition of make-up water and drilling fluid products (Appendix 4) during drilling operations to maintain the desired properties to control borehole fluid loss or gain as drilling progresses.

In the event of significant observed lost circulation to the formation, the drilling team will consider appropriate action, which typically includes reducing the mud density (water dilution) and utilizing/adding lost circulation materials (LCM) such as Walnut and Sawdust/MaxiSeal to the drilling fluid to help cure/seal the loss zone. LCM is mixed in the drilling fluid, then pumped to the loss zone through the drill pipe. Repeated LCM treatments or a cement plug across the loss zone may be required depending on severity. Significant loss zones are not anticipated. The predicted intercepted lithology for all proposed wells is primarily homogeneous sediments, with mostly very fine particle size, including clay and claystone, with low to no fracturing. 3PL is unaware of any underground mine workings in the Project area. SDS for LCM are included in Appendix 4. None of the proposed LCM are hazardous.

In the event of a significant fluid gain, such as artesian flows, the drilling team will consider appropriate action which generally includes increasing the mud density to balance formation pressures. Appropriate weighting materials (e.g., Barite, Soda Ash) will be added to the mud system to obtain and maintain the appropriate mud density.

A qualified professional will be at the drill site at all times during drilling to record important hydrogeological information such as water table levels, water inflow rates, fracture/fault zones, voids, zones of lost circulation, and other useful information including monitoring for surface leaks, should they occur. Water flow amounts exceeding that used for establishing normal drilling circulation will be monitored for quantity and color. The qualified professional will help manage flow and recommend additives to control mud weight, filtrate, and other properties while drilling to minimize lost circulation and/or fluid flow.

3PL is proposing to use a portable, fully-contained mud system with the capability to remove drill cuttings (solids) from the circulating drilling fluid to maintain the desired fluid density. The drilling fluid (mud) is captured at the surface drill collar, routed to the mud system where the combination of a shaking screen, centrifuge, and select polymers remove the fine (<200 microns) rock cuttings (drill solids) produced by the rotating diamond bit while advancing the borehole through the country bedrock. No uncontrolled flow of drilling fluids will be allowed.

Processed drilling fluid is then reconditioned as needed with additional water and other drilling fluid products, then returned to the borehole to maintain circulation in a closed loop. Drilling fluids will not be discharged to the drill site, ground surface, or to the surrounding environment during drilling operations. Sumps have been included in the proposed drill site design for supplementary containment capacity, transfer of fluids and solids, and emergency or upset conditions.

Dewatered drill solids are deposited via a waste chute into a steel bulk container, such as a roll-off bin, for subsequent characterization and disposal at an appropriate facility. Bulk containers will be covered when not in use. Any seepage from dewatered drill solids will be contained within the bulk container.

The maximum expected volume of dewatered drill solids produced from each well is calculated using the borehole volume and subtracting the volume of cores that are recovered. The formula below was used to calculate the borehole and retained sample volume difference to produce the volume of drill solids produced from the bit face:

$$\pi [(Borehole OD)^2 - (Core OD)^2] (h) / 576 = \text{Annular Volume in Cubic Feet}$$

(Where OD is outside diameter in inches, h = borehole length in feet, $\pi = 3.141592$).

Total drill solids volume is summarized in Table 2.

Table 2: Estimated Drill Solids Volume in Cubic Feet.

Well Name	Li 10-28	Li 11-18
Drill Solids Volume (ft ³)	2,480	2,345
Drill Solids Volume (gal)	18,551	17,542

The sulfide concentration of the drill solids is expected to be very low (<0.01%) due to the inherent redox conditions in the alkaline, hypersaline formation brine. Salts or other content in the drill solids potentially requiring special handling will be determined by characterization during and after drilling. All drill solids will be fully contained on site until appropriately characterized. Drill solids may be characterized using Nevada Division of Environmental Protection (NDEP) Profile I metals, Meteoric Water Mobility Procedure for Profile I constituents, Acid-Base Accounting, Volatile Organic Compounds, Total Petroleum Hydrocarbons, and/or Toxic Characteristic Leaching Procedure to determine the appropriate disposal method or according to disposal facility requirements. Analysis results will determine if dewatered drill solids will be stabilized on-site or shipped to the appropriate licensed facility for recovery or disposal.

Once each well is completed, all fluid used in drilling is evacuated from the well bore. When drilling of the production hole is complete, production casing is placed in the hole and cemented. During cementing, cement is pumped down the casing followed by a wiper/bumper plug and freshwater displacement fluid. The bumper plug pushes all drilling mud and cement down the hole and around the backside of the production casing. The cement volume quantity is calculated to reach the top of the outside of the casing with at least 30 percent excess. The excess cement ensures all drilling mud and some cement is evacuated from the hole. The displaced drilling mud and excess cement will be pumped to containment for reuse in drilling of a subsequent well, if available, or characterization to determine an appropriate disposal method.

None of the 292 known oil and gas wells in Railroad Valley have encountered oil or gas at the Project's proposed depths for drilling. No open boreholes exist on any of the drill sites and well LD 1-32 is the only existing lithium well. There are no known open boreholes within 300 feet of any of the proposed drill sites.

4.1 Well Abandonment

All holes drilled for the purpose of mineral exploration shall be plugged and sealed in a manner consistent with State of Nevada regulations and the stricter requirements described below. Project activities will be conducted in a manner that prevents adverse changes in groundwater quality and quantity. Abandonment of drill holes shall ensure the safety of people, livestock, wildlife, and machinery within the project area. A drill rig with appropriate support equipment will be used to abandon each well when it is no longer needed.

Pursuant to Nevada Administrative Code 534B Section 35.1(a), perforated sections of the casing, as well as the portion of unperforated casing occurring below the uppermost perforations will be plugged by placing cement grout by tremie pipe in an upward direction from the bottom of the well to 100 feet above the uppermost perforated casing. Unperforated portions of the well 100 feet above the plug will be plugged pursuant to NAC 534B Sec 35.3 with uncontaminated fill to within 20 feet of the surface. The remaining 20 feet of casing will be plugged with cement grout. Perforation of blank casing is not required by NAC 534B or the Nevada Division of Minerals (Lowell Price, NDOM Fluid Minerals Program Manager, Personal Communication, 1 July 2020).

A qualified professional will be at the drill site to record important hydrogeological information such as water table levels, water inflow rates, fracture/fault zones, voids, zones of lost circulation, and other useful information.

During abandonment, a cement grout meeting the formulation standards required by Nevada Administrative Code (NAC) 534.060 will be mixed at the surface, pumped under pressure through the drill pipe, and circulated from the bottom of the borehole through the annulus in a manner meeting the general plugging requirements of NAC 534.420 and NAC 534.426 for general or artesian conditions. The use of cement grout and tremie placement method will isolate the borehole from the local hydrogeological regime and prevent the vertical movement of any groundwater penetrated by the borehole. This will include the annular space surrounding any casing left down the hole.

In contrast to current Nevada revised regulations NAC 534.4371, which allow screened bentonite chips or uncontaminated soil to be poured down a drill hole to plug it if the hole ends above the water table, all plugging material will be placed by tremie pipe or through the drill rods from the bottom of the hole upward. Abandonment material may be poured into the hole from the surface only if the drop is less than 30 feet. The cement cap will be placed directly on top of the settled and set-up abandonment material. When placed, the cement grout will be physically and chemically stable in the borehole regardless of formation pressure or groundwater quality encountered along the length of the borehole. Zones of lost circulation below the water table will be evaluated by the on-site qualified professional to ensure proper plugging. The zone will be indicated on the BLM Borehole Abandonment Report, as described under Well Abandonment Reporting, below, and explain what was done to reestablish circulation or how the zone was isolated with a drill hole plug/packer immediately above the zone during abandonment. Drill rods will never be greased to remedy zones of lost circulation. In the case

that circulation is lost and does not return, the drill hole must be plugged from bottom to top in such a way that the plugging medium supports the surface cement plug.

After the rig has left the site and the cement grout has been allowed to stabilize in the borehole, a 20-foot cement surface plug extending from three (3) feet below the ground surface will be placed in the top of each borehole. Portland cement mixed with water and aggregates, or bagged cement mixed with water, will be used for the surface plug. Any remaining surface casing will be removed below the ground surface to a sufficient depth that will not interfere with general reclamation requirements to eliminate physical hazards to humans and wild or domestic animals as well as to prevent ponding of water directly over the borehole, allow for placement of growth media, and allow for passage of earthmoving equipment required for reclamation operations.

4.2 *Well Abandonment Reporting*

A record of each borehole will be kept by 3PL in the BLM Borehole Abandonment Report as required by NAC 534.4369 to demonstrate:

- The dates on which the borehole is constructed and plugged;
- The location of the borehole as shown by the public land survey system;
- The depth and diameter of the borehole;
- The depth at which groundwater is encountered in the borehole; and,
- The methods and materials used to plug the borehole.

Driller and geological logs typically record this information and also contain information concerning significant changes in fluid losses or gains as drilling progresses in each borehole. The type and volume of materials used in zones of significant gain or loss indicate the hydrological conditions encountered as borehole drilling progresses. The depth to the first instance of groundwater is difficult to determine with certainty in a fluid drilled borehole and any such data reported may not reflect actual subsurface hydrological conditions.

4.3 *Inspections and Compliance*

3PL representatives will be present on site during all active operations and a BLM mineral administrator will conduct regular inspections to ensure compliance. Continued monitoring will occur by the operator and BLM during reclamation activities, including any required treatments of noxious weeds. Interim progress of reclamation will be monitored as appropriate by the BLM and 3PL.

Inspection and monitoring by the operator and the BLM will ensure the SOPs, environmental protection measures, mitigation, and reclamation are working as designed to keep the Project sites and surrounding area free of groundwater or surface water contamination. BLM National BMP direction will be followed to ensure water resource protection and monitoring. A sufficient reclamation bond will also be in place with the BLM prior to the initiation surface disturbing activities in case the operator is unable or unwilling to complete the final reclamation of the project.

4.4 Proposed Mitigation Measures

The operator will notify the BLM within 24 hours if there is any information collected that may indicate unresolved concerns at depth during drilling or during plugging procedures that indicate a negative impact to groundwater or surface water resources.

4.5 Fluid Sampling

No fluid pumped from the proposed wells will be discharged to the surface without prior characterization and authorization from the BLM and appropriate State agencies. During pumping and fluid sampling of each well, ultrasonic and mechanical flow meters equipped with totalizers will be installed and used to record volume of fluid pumped. Total volume of fluid pumped at each well will be reported to the Nevada Division of Minerals.

Samples of formation fluid will be collected from all proposed wells to analyze constituent concentration and identify economic dissolved mineral resources. The quantity of fluid pumped from each well will be selected based on subsurface geochemistry. Pursuant to United States Environmental Protection Agency 2015 Standard Operating Procedure for collecting a representative sample of formation fluid, a volume of fluid will be removed from each well until the stabilization of water-quality-indicator parameters (e.g., pH and specific electrical conductance) are observed with field instrumentation. To calculate a conservative estimate of the total volume pumped, at least three (3) casing volumes of fluid are assumed pumped from each well at each sampling event (EPA, 2015). All pumped fluid will be placed in a portable 20,000-gallon steel storage tank located near the sump and adjacent to the drill site (Figures 7 and 8). Conservatively, removal of samples up to 400 gallons of formation fluid each is also assumed. Wells may be sampled at one or more intervals, increasing the total volume of fluid pumped from the formation. Proposed wells Li 10-28 and Li 11-18 will have the similar total volumes pumped with up to seven (7) test intervals and total estimated pumped volume of 82,656 gallons. This volume would be produced over a period of about one week (10,080 minutes), or an average removal rate of about 7.8 gallons per minute (gpm). No more than 20,000 gallons of produced formation fluid will be stored on a drill site in steel tanks at one time. Due to the relatively low pumping rate, drill site space considerations, and operational needs, only one (1) 20,000-gallon steel tank for formation fluid storage will be on site and filled at a time. Artesian conditions are not expected and fluid production can and will be halted as needed. No fluid sampling is proposed from existing well LD 1-32 at this time. Proposed total volumes of fluid produced from each well are summarized in Table 3.

Table 3: Proposed Total Pumped Volumes for Sampling and Evacuation

Well	Depth (ft)	Diameter (in)	Casing Vol (gal)	Test Intervals (#)	¹ Total Volume Pumped (gal)
Li 10-28	2,300	6.366	3802.7	7	82,656
Li 11-18	2,300	6.366	3802.7	7	82,656

$$1 - \text{Total volume pumped} = [\pi * ((ID/2)/12)^2 * (\text{Well Depth}) * 7.48 * 3 + 400] * (\# \text{ of Test Intervals})$$

All pumped fluid will be transported and disposed at the appropriate authorized facility.

Further discussion regarding aquifer response of Project area groundwater to the proposed pumping quantities is included in Appendix 5. Depth of potential drawdown of groundwater in response to pumping will vary according to the rates and quantities pumped, however, the drawdown at wells Li 10-28 and Li 11-18 is estimated to be 0.4 feet at 5,280 feet (one (1) mile) from the wellhead. There are no springs, existing water rights, geothermal resources, or habitat supporting threatened and/or endangered species within 5,280 feet of any proposed well. No adverse impact to regional springs, existing water rights, geothermal resources, or critical habitat, and thereby threatened or endangered species, is anticipated due to Project-related activities.

5.0 Spill Prevention and Maintenance

5.1 Objectives and General Information

3PL has developed spill prevention procedures for implementation during the Project. The purpose of these procedures is to prevent or reduce materials that may be considered as pollutants to be discharged to the environment. These procedures will promote the safety and awareness of personnel, eliminate, or reduce the potential of releases (regardless of size), and ensure that mitigation, storage, and disposal procedures are adequate for environmental protection and regulatory compliance. Specific tasks and procedures for spill prevention and control are as follows:

- All drill sites will be maintained in a clean and well-organized manner. Each site will be properly equipped so maintenance and cleanup of leaks or spills will occur in a proper and timely manner.
- Information on proper storage, cleanup procedures, and reporting protocols will be posted at a visible and accessible location at all times. Manufacturer's SDS will be made available upon request.
- Drill sites will satisfy containment requirements such as drum pans for containment and control of unforeseen leaks and spills.
- Products and materials will not be stored in a manner on individual drill sites where the products and materials will be susceptible to meteoric precipitation. Products will be protected by use of storage trailers, pallets, tarps, or other appropriate covers.

5.2 Equipment Fueling

Designated fueling areas will be located on a level-graded area (drill sites) and will be protected from run on or runoff. During fueling, vehicles will be attended at all times. Fueling will not occur in drainages.

Fueling equipment will be equipped with an authorized shut-off nozzle to contain drips and to eliminate accidental overflowing. The practice of "topping off" the tank will not be allowed.

5.3 Preventative Maintenance

Good housekeeping practices are designed to minimize amounts of materials stored and the potential release of these products. Listed below are good housekeeping practices to be followed during the exploration Project:

- Only enough products required to do the job at hand will be stored on individual drill sites.
- Materials will be stored in a neat and orderly manner in appropriate containers with approved lids or sealed and enclosed by water resistant covering, as needed.
- Products will be kept in original containers with the original manufacturer's label.
- Manufacturer's recommendations for proper storage, use, and disposal of each product will be followed.
- The Project Manager will inspect the drill sites to ensure proper use and disposal of materials on site. Inspections will identify problems and outline a timeframe for their correction.

Contractors will have vehicle preventative maintenance programs in place to ensure vehicles are utilized under optimum operating parameters and to ensure hoses and fittings are in good condition and leak-free. The operator, mechanic, tool pusher, or other designee is responsible to execute the repairs or preventative maintenance tasks. These tasks will be documented through the use of vehicle maintenance logs. Equipment in need of repair will not be put into fleet service until repairs are fully completed.

5.4 Source Identification

Potential sources of pollutants from drill rigs, service vehicles, and other equipment include oil, hydraulic fluids, fuel, and lubricating grease. Additional sources of pollutants may include drilling fluids (bentonite, polymers, and cement), borehole plugging materials, solvents, trash, and other debris. These pollutants are not expected to come into contact with on-site soils or surface waters; however, Best Management Practices (BMPs) will be employed to prevent potential release of contaminants to the environment.

Non-hazardous Project-related refuse would be collected in approved trash bins and/or containers and hauled from the site by 3PL or their contractors for disposal on a daily basis. The bins and/or containers will be equipped with lids. Debris that may have a hazardous characteristic, residue, or fluids will not be disposed of in these trash bins. To minimize impacts during precipitation events, trash bins will be regularly inspected for leaks and the lids will remain closed except when depositing debris. The trash bins will not contain materials that may attract wildlife (food items, etc.) and will be emptied on a regular basis.

5.5 Spill Contingency Plan

Materials and equipment (spill kits) necessary for spill cleanup will be kept in at each operating area. Equipment and materials will include, but not limited to brooms, dust pans, rags, gloves, goggles,

sorbent materials, sand, sawdust, and plastic / metal trash containers specifically designed for this purpose.

Well-maintained equipment will be used to perform the work required during this exploration Project. When practicable, equipment maintenance will be performed off-site. In the event of oil, fuel, and lubricating grease leaks, cleanup will be conducted as soon as possible. If the leak is on compacted soil, an oil-absorbing product, such as Absorb[®], may be applied. Once the cleanup product has absorbed the leak, the product will be swept up into watertight drums or bins, labeled, stored, and disposed of according to federal, state, or local regulations. If the leak occurs on uncompacted soil, the contaminated soil will be removed, managed, and disposed according to federal, state, or local regulations. In either case of compacted and uncompacted soils, soils will be “loosened,” and removal of soil will occur to the depth required to capture the contaminated soils and/or materials.

The Spill Prevention and Maintenance procedures and BMPs will be adjusted to include measures that will mitigate reoccurrence and ensure that cleanup procedures are adequate. A description of the spill, cause, cleanup measures, and disposal method will be documented and reported as appropriate.

5.6 Spill Response

Quick and correct actions are important to a material spill. To ensure employee safety and protection of the environment, employees will treat spills as if hazardous. Employees will implement the use of SDS as needed. Regardless of size, spills will be reported to the appropriate 3PL supervisor.

The following actions will be taken in the event of a material spill:

- Notify the supervisor or Project Manager immediately. The supervisor or Project Manager will oversee the response and cleanup of material releases.
- Use the proper Personal Protective Equipment (PPE).
- Stop the release of material if safe to do so.
- Proceed with containing and controlling the spread of the released material. Use the on-hand supply of erosion control structures and/or create dirt berms, as feasible and necessary. Also utilize the materials and equipment stored on site to control the spill.
- Do not walk on or touch the spilled material.
- Avoid inhalation of gases, fumes, and smoke.
- Never assume that gases or vapors are harmless. Be aware of possible harmful colorless or odorless gases or vapors.
- The 3PL Project Manager will oversee the response and cleanup of hazardous materials releases.
- Sweep up dry spills.
- Contain wet spills and remove standing liquids and wet soils. Soils will be removed at a depth that is adequate to remove contaminated material.
- Only a reputable, licensed company will be used to cleanup large spills and dispose of contaminated materials.
- Store contaminated materials in appropriate and approved containers.

Nevada Division of Minerals: Mr. Cortney Luxford
Dissolved Mineral Resource Exploration Well Permit Applications
3PL RRV II Exploration Project (NVN-100052)
9 November 2021

- Properly label containers according to federal, state, and local requirements.
- Comply with storage requirements, such as time limits.
- A spill report must be completed and forwarded to the 3PL representative within eight hours. Proper regulatory agency notification will then follow.

5.7 Spill Reporting

All spills, regardless of size or quantity, must be reported to the 3PL representative. All spills meeting the following criteria must be reported to the appropriate regulatory agency:

- Quantity greater than 25 gallons or 200 pounds released to soil or other surfaces of land.
- Discovered in at least 3 cubic yards of soil during excavation.
- Discovered in or on ground water.
- Within 24 hours of an identified spill, the Project Manager, or a designated representative, will notify the following local and state agencies as required:
 - Nevada Department of Environmental Protection: 1-888-331-6337
 - Bureau of Land Management, Tonopah Field Office: 1-775-482-7800
- Specific information to be forwarded to these agencies includes the following:
 - Name of employee reporting release.
 - Potential threats to public safety.
 - Possibilities of release entering waterways, drainages, etc.
 - Cleanup procedures implemented for spill remediation.
 - Defined follow up procedures to be used to satisfy health, safety, environmental, and regulatory requirements.

5.8 Petroleum Contaminated Soils (PCS)

PCS generated as a result of any spill will be disposed within a closed bin and transported off-site for proper disposal.

6.0 References

Core Laboratories. 2021. Owen Oil Tools Charge Performance Selection Guide Options. Available: <https://www.corelab.com/owen/cms/html/charge-performance-data.aspx>

Should you have any questions, please feel free to contact Mr. Vincent Ramirez at (775) 434-7333 or by email (vince@3ploperating.com), or Matt Dusenbury at (775) 379-9148 or by email (mpdusenbury@minesgroup.com). We look forward to working with you on this effort.

Best regards,



Matt Dusenbury
Environmental Project Manager

Nevada Division of Minerals: Mr. Cortney Luxford
Dissolved Mineral Resource Exploration Well Permit Applications
3PL RRV II Exploration Project (NVN-100052)
9 November 2021

The MINES Group, Inc.
On Behalf of 3PL Operating, Inc.

Distribution:

NDOM	3PL Operating, Inc.
Mr. Cortney Luxford	James Melland, Vincent Ramirez, Mark Zouvas
Electronic and Hard Copies: Cover letter; DMRE x 2 (Li 10-28, 11-18)	Electronic Copies: 3PL-RRV-II-DMRE-Applications-20211108mpd.pdf
Filename: 3PL-RRV-II-DMRE-Cover-Letter-20211108mpd	



13 May 2022

Via E-Mail: (cluxford@minerals.nv.gov)

Via Certified Mail

Mr. Cortney Luxford
Fluid Minerals Program Manager Nevada
Nevada Division of Minerals
400 West King Street, Suite. 106
Carson City, NV 89703

**Re: 3PL RRV II Exploration Project NVN-100052
Dissolved Mineral Resource Exploration Well Permit W0008
Proposed Revision to Annular Spacing and Surface Casing Length**

Dear Messrs. Luxford and Visher,

Pursuant to Nevada Administrative Code (NAC) 534B.110, 3PL Operating, Inc. (3PL) submits the following amendment to Dissolved Mineral Resource Exploration (DMRE) Permit W0008 (Li 11-18).

3PL proposes two modifications to the authorized Li 11-18 well configuration as follows:

1. Reduce the annular spacing of the production casing string from 12 ¼ to 9 ⅝ -inch diameter;
2. Reduce the authorized length of surface casing from 500 to 420 feet below ground surface (bgs).

The revised well diagram is included in Figure 1, Appendix 1. Detail regarding the proposed modifications is included in the following.

1.0 Annular Spacing Modification

3PL respectfully requests exemption from NAC 534B.160.2(b)(2) for Well Li 11-18 to ensure conformance with best practices for commensurate wells, best represented by common practice in oil and gas. Regulatory requirement for a two (2)-inch annular spacing for the production casing string references water well construction and is not optimally suited for the proposed exploration activity at Li 11-18. Due to the depth of the well and 3PL's drilling practices regarding the size and specification of the rig used, casing, and completions that include perforations through steel and cement, there are no safety issues, engineering issues, or potential degradation of Waters of the State with a proposed narrower annular space.

3PL proposes reduction of the drilled production hole diameter from 12 ¼ to 9 ⅝ -inches. The authorized seven (7)-inch casing will be cemented in place by conventional oil and gas methods utilizing a float collar and wiper plug to fill the 9 ⅝ -inch by seven (7)-inch annular space with 13.5 ppg cement from the casing shoe to surface. This is universally accepted as the most effective method for achieving a uniform, continuous cement sheath to provide wellbore integrity and hydraulic isolation.

1. A "Tremie Pipe" is not used to set 3PL's proposed cement, and this is the main purpose of the two (2)-inch annular space. Reducing the annular space to one (1) inch is consistent with oil and gas casing practices. A partial list of oil and gas wells with this design is included in Appendix 2 (CalGEM, 2022). It is not feasible to cement the production casing with a tremie pipe at the proposed depths.
2. The large annular space of the authorized design presents risk due to the low annular-velocity of the cement column as the annular space is filled from total depth. Low annular velocity can result in cement channeling and contamination, both of which have significant potential to negatively affect the quality of cement bond and hydraulic isolation.
3. The large annular space of the original design creates 2 ½ inches of cement that 3PL must perforate when testing fluids. This requires particularly large perforation guns and additional risk of the loss of the well if full penetration is incomplete. A reduction to a one (1)-inch annular space is consistent with oil and gas wells in this regard.
4. There are no high temperature additives in the proposed cement to complicate its integrity.
5. 3PL will run a cement bond log to check for cement bond integrity.
6. If cement integrity is insufficient to isolate freshwater, 3PL will perform a "squeeze job" and complete the cementing process to specifications, and rerun a cement bond log.
7. Using less cement in the annular space reduces the risk of hydro-fracking the strata with cement due to the low pore pressure of the shallow unconsolidated sediments. An alternative is for 3PL to use low density cement, but this inhibits recognition of bonding on the cement bond log.
8. The production casing string runs from surface to total depth, and sits inside of the surface casing string. The surface casing string is set several hundred feet below fresh water (please see Section 2.0) and is also cemented; it is "Tremie Pipe" capable, since 3PL does not propose to substantively change the surface casing design. Freshwater is measured at 40 feet bgs in this well.

2.0 Surface Casing Modification

3PL proposes to modify the surface casing configuration of its authorized well 11-18 (W0008). 3PL will reduce the authorized length of surface casing at 11-18 from 500 feet below ground surface (bgs) to 420 feet bgs. The revised well diagram is included in Figure 1, Appendix 1.

Updated Vertical Electrical Sounding (VES) surveys are now available from April of 2022. VES results indicate fresh water extends from about 40 feet bgs to about 235 feet bgs, transitioning into significantly saline water as depth increases. Results indicate the interface of heavy brine with saline groundwater is nearer the surface than previously proposed. An updated well prognosis for 11-18 is included in Figure 2, Appendix 1. Base of saline groundwater is anticipated at 410 feet bgs and the proposed surface casing will extend at least 10 additional feet to 420 feet bgs. Comprehensive VES data is included in Appendix 3. Reduction in the surface casing length will facilitate exploration of shallower brine and preclude the need to penetrate two (2) casing strings. No changes are proposed to well diameter.

Nevada Division of Minerals: Mr. Cortney Luxford
Dissolved Mineral Resource Exploration Well Permit Applications
3PL RRV II Exploration Project (NVN-100052)
13 May 2022

Anticipated total well depth for Li 11-18 is estimated at 2,207 feet bgs, shallower than the authorized depth of 2,300 feet bgs. 3PL will not modify its bonding or Notice (NVN-100052) to reflect the shallower well, however, as the deeper authorization and bonding is more conservative and allows for more operational flexibility.

3.0 References

California Geologic Energy Management Division. 2022. CalGEM GIS Well Finder Available:
<https://maps.conservation.ca.gov/doggr/wellfinder/#openModal/-118.94276/37.11133/6>

Should you have any questions, please feel free to contact Mr. Vincent Ramirez at (775) 434-7333 or by email (vince@3ploperating.com), or Matt Dusenbury at (775) 379-9148 or by email (mpdusenbury@minesgroup.com). We look forward to working with you on this effort.

Best regards,

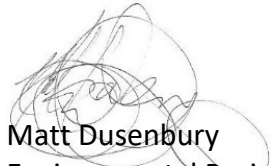

Matt Dusenbury
Environmental Project Manager
The MINES Group, Inc.
On Behalf of 3PL Operating, Inc.

Distribution:

NDOM	3PL Operating, Inc.
Mr. Cortney Luxford	Jake Zachry, Vincent Ramirez, Mark Zouvas
Electronic and Hard Copies: Cover letter	Electronic Copies: 3PL-RRV-II-DMRE-Amendment1-20220513mpd.pdf
Filename: 3PL-RRV-II-DMRE-Amend1-Cover-Letter-20220512mpd	

Nevada Division of Minerals: Mr. Cortney Luxford
Dissolved Mineral Resource Exploration Well Permit Applications
3PL RRV II Exploration Project (NVN-100052)
13 May 2022

Appendix 1
Well Bore Diagram
Li 11-18

Well Schematic
 3PL Operating Inc.
RRV Lithium Evaluation Well
 Li #11-18 (57E)
 NW/4 NW/4 NW/4 NW/4 18-7N-57E, MD B&M, Nye Co, NV
 GL = 4708' KB = TBD On-Site

Proposed Completion

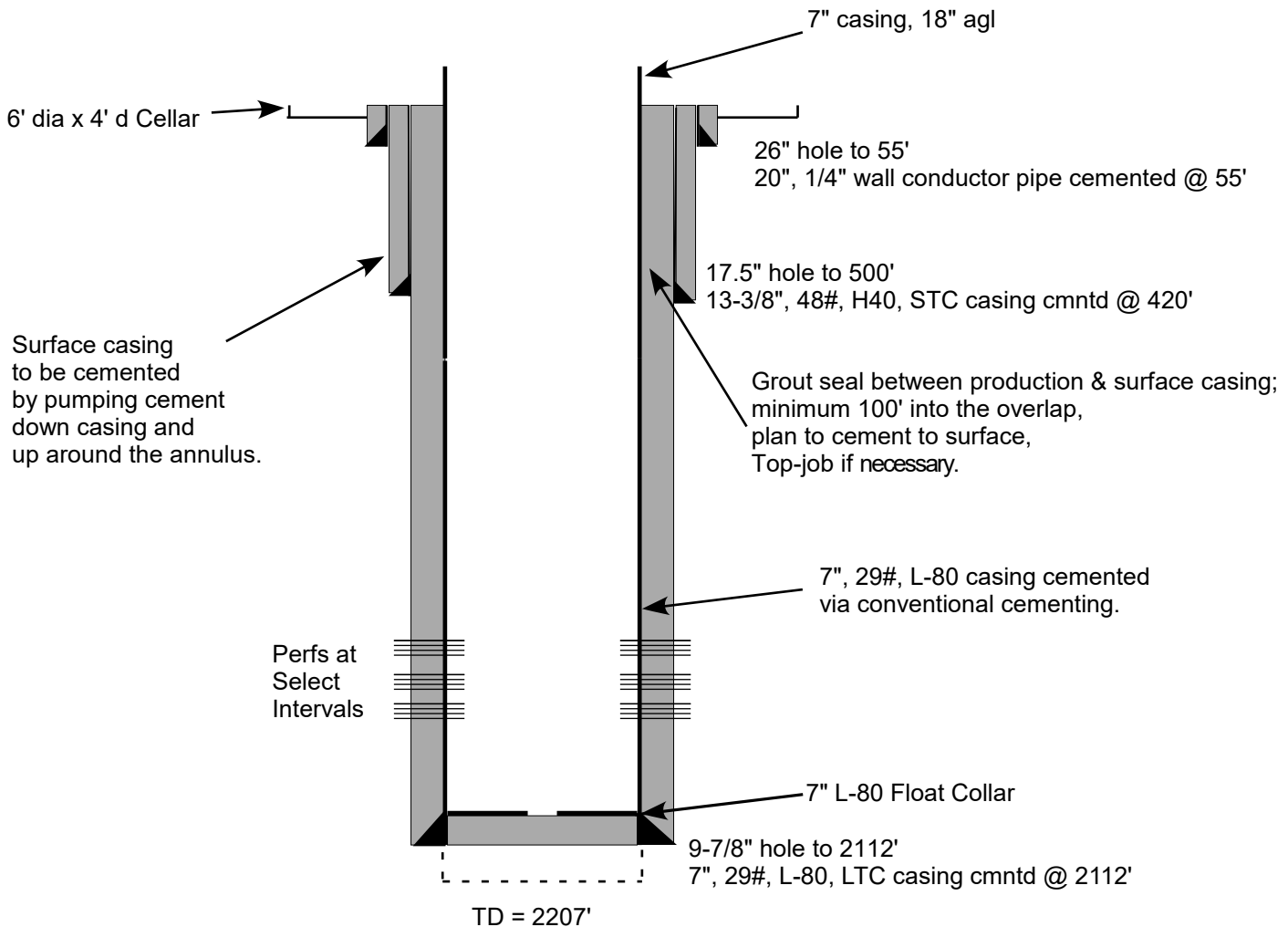

NOTES:

1. All casing sizes are actual OD.
2. This well design is for evaluation wells needing isolated samples and flow rates.
3. Hole depths will be adjusted to fit casing.
4. All depths referenced to ground level.
5. 8-3/4" pilot hole will be drilled for surface and production hole.

Figure 1.

Drawn by: James E. Melland, PE, PG
 4/29/2022

Revised by: Jacob Zachry, PE
 5/12/2022

Li 11-18
WELL PROGNOSIS
3PL OPERATING INC.

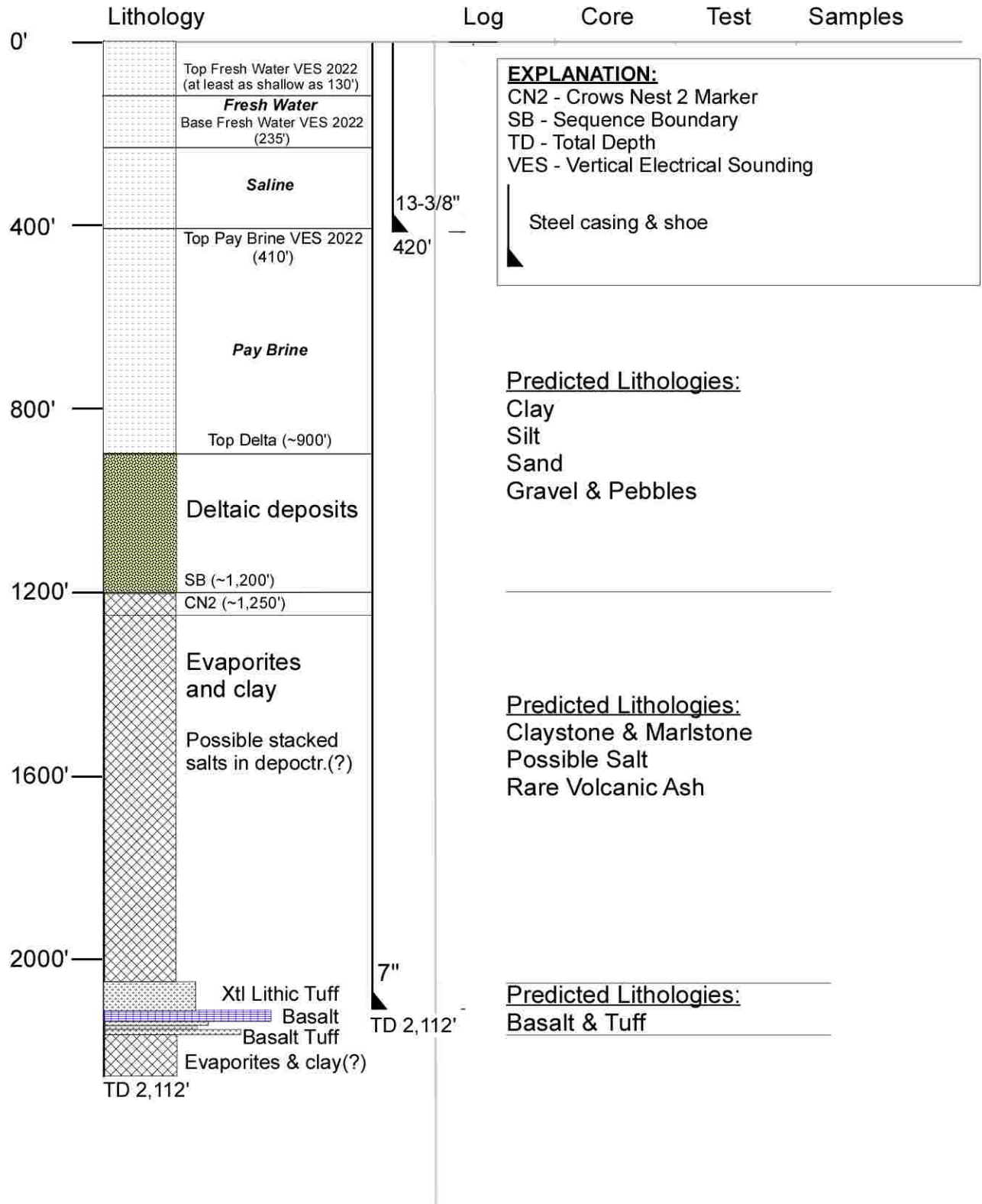

Figure 2.

Appendix 2
List of Authorized Wells with <2-inch Annular Space

Field	Lease	Well Name	API Number	Section	Township	Range
Midway Sunset	Leutholtz A	298	0403068442	22	11N	23W
Midway Sunset	Leutholtz A	272	0403068424	22	11N	23W
Midway Sunset	Leutholtz A	300	0403068430	22	11N	23W
Midway Sunset	Leutholtz A	302	0403068447	22	11N	23W
Midway Sunset	Leutholtz A	274	0403068439	22	11N	23W
Midway Sunset	Leutholtz A	278	0403068425	22	11N	23W
Midway Sunset	Leutholtz A	295	0403068464	22	11N	23W

Nevada Division of Minerals: Mr. Cortney Luxford
Dissolved Mineral Resource Exploration Well Permit Applications
3PL RRV II Exploration Project (NVN-100052)
13 May 2022

Appendix 3
Vertical Electrical Sounding Data
April 2022

VES Survey Acquired at Location of Well Li 11-18

April 19, 2022

Field Party: Carmen Bushorn, Shane Steinert, Vicente Ramirez

